

Patternübersicht

- Western Riding
 - Pattern 3
 - LK 1/2
 - Pattern 3
 - LK 3
- Senior Superhorse
 - Pattern 3
 - LK 1/2
- Reining
 - Pattern 6
 - LK 1/2 A
 - Pattern 6
 - LK 1/2 B
 - Pattern 5
 - LK 3 A
 - Pattern 5
 - LK 3 B
 - Pattern 14
 - LK 4
- Ranch Riding (2017)
 - Pattern 2
 - LK 1 A
 - Pattern 2
 - LK 2 A
 - Pattern 2
 - LK 1 B
 - Pattern 2
 - LK 2 B
 - Pattern 7
 - LK 3 A
 - Pattern 7
 - LK 3 B
 - Pattern 5
 - LK 4 A
 - Pattern 5
 - LK 4 B
 - Pattern 5
 - LK 5 A
 - Pattern 5
 - LK 5 B

Trail Horse LK 1 / LK 2

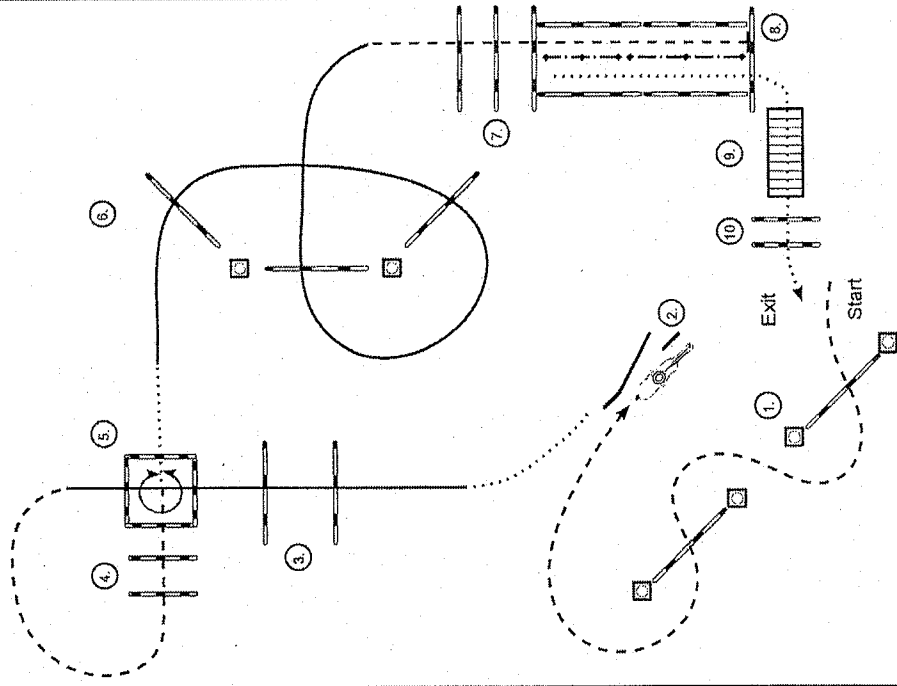

1. Jog (Stalom) over Poles to Gate
2. Gate (L/H)
3. Lope over Poles (LL)
4. Jog over Poles into Box
5. 360° Turn (R or L)
6. Walk out
7. Jog over Poles (RL)
8. Back Up
9. Walk out Chute over Bridge
10. Walk over Poles to Exit

- Walk (dotted line)
- Jog (dashed line)
- Lope (dotted line)
- BackUp (dotted line with arrows)
- Sidepass (solid line with arrows)
- Lead Change (solid line with X)

Trail Horse LK1B / LK 5B

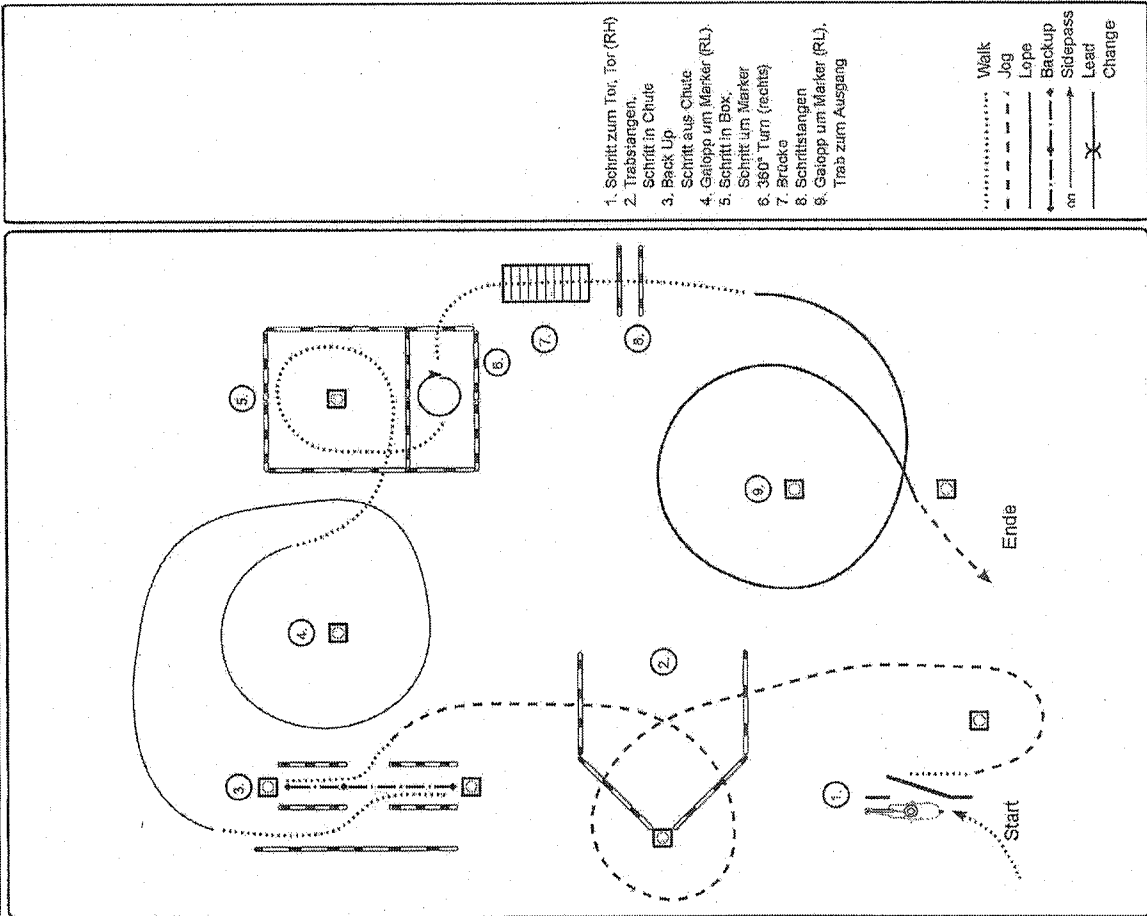

Trail Horse LK 4A / LKSA

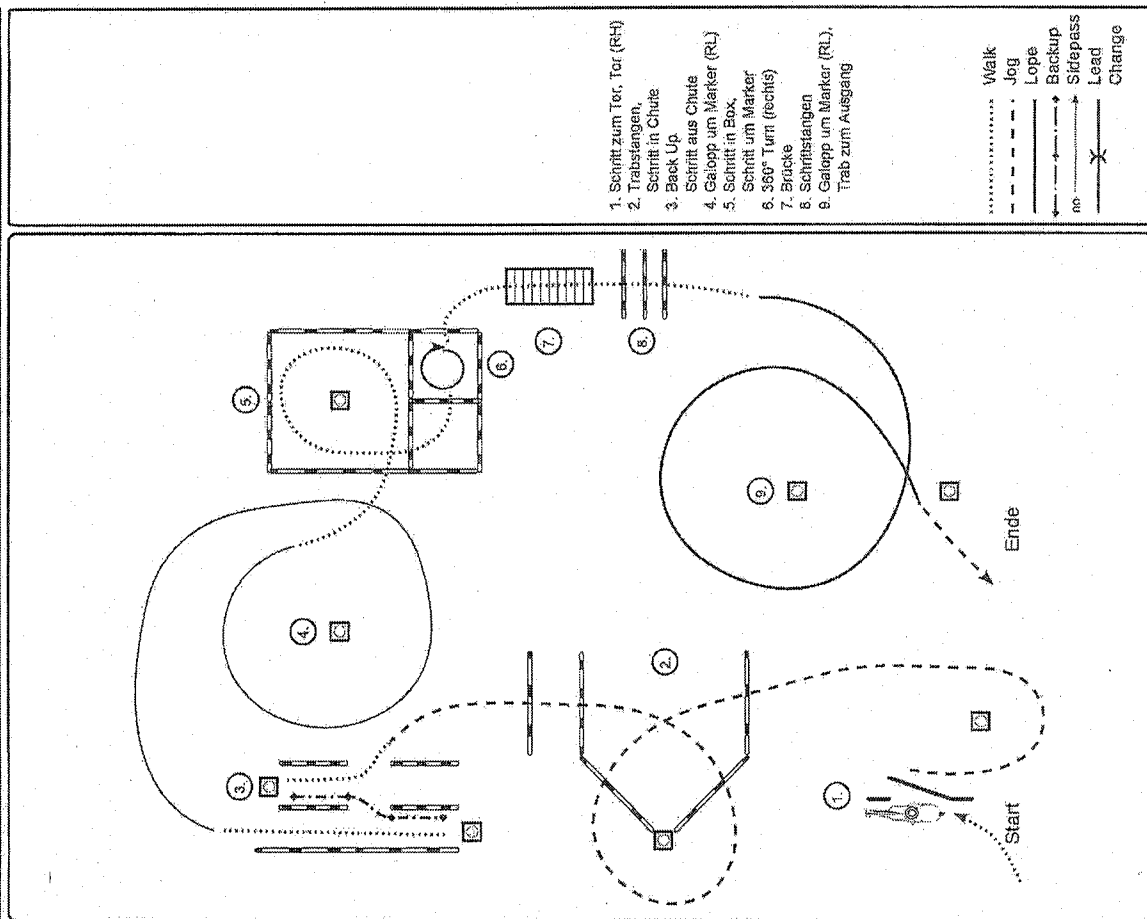

Trail Horse in Hand

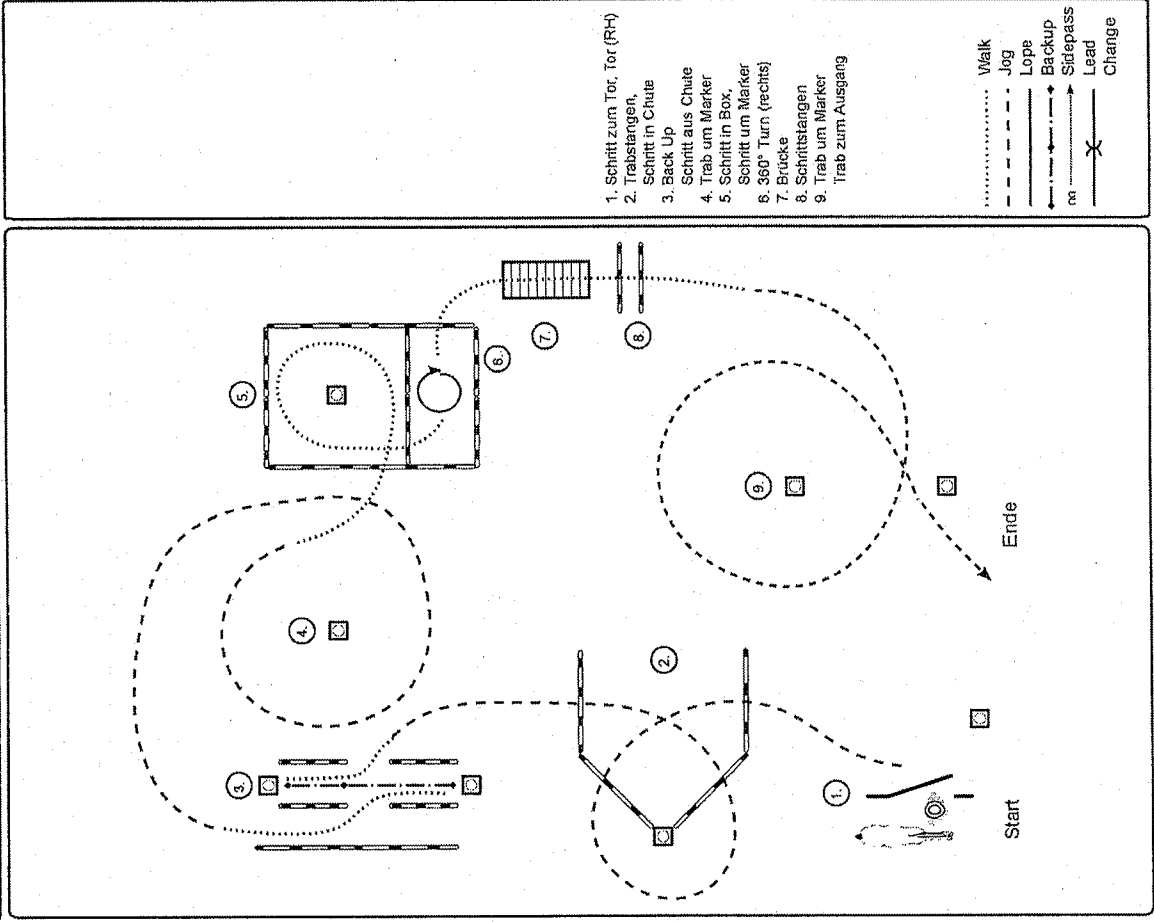

Trail Horse Walk-Trot

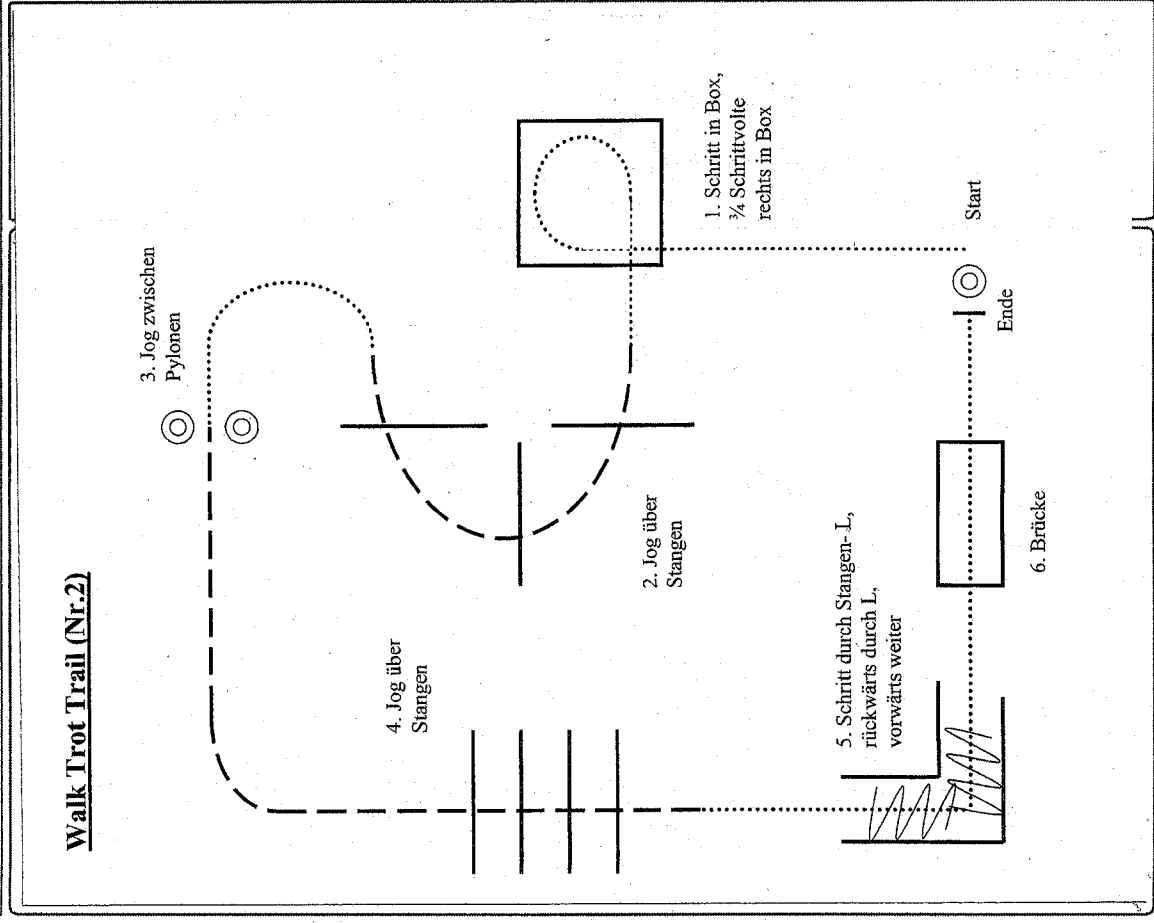

Showmanship at Halter LK 1 / LK 2

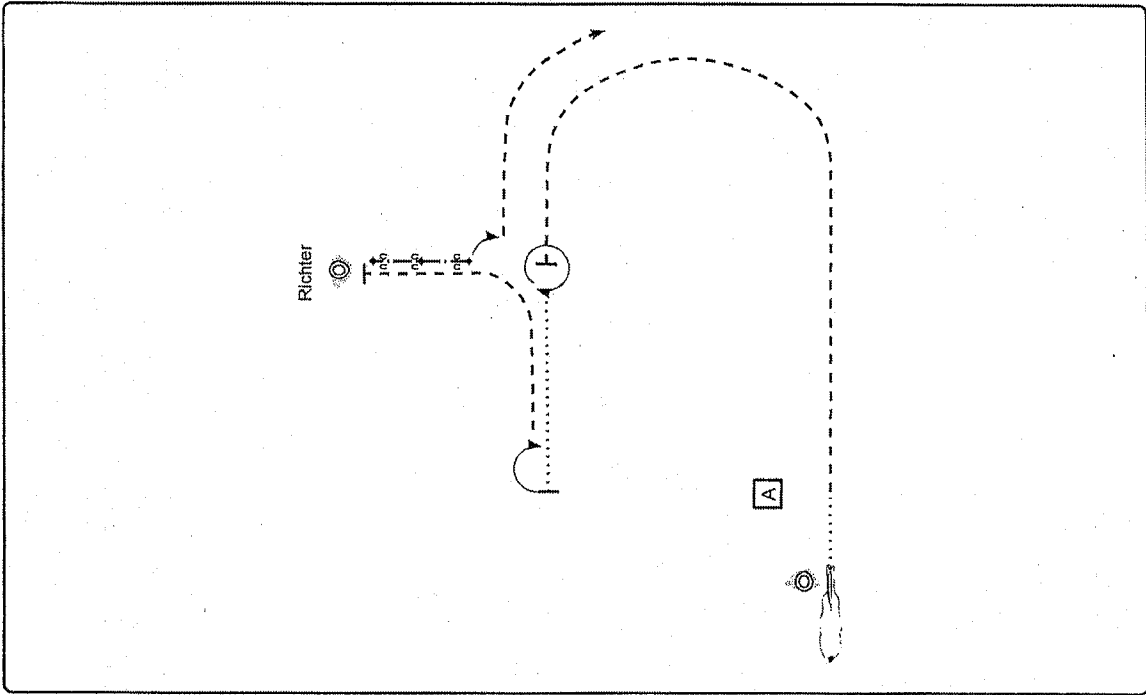

- Sell Up vor A
 1. Walk bis A
 2. einen halben Zirkel im Jog bis auf Höhe des Richters - Stop
 3. 360° Turn
 4. Walk bis auf Höhe A - Stop
 5. 180° Turn
 6. Jog bis zum Richter - Stop
 7. Sell Up
 8. Back Up
 9. 90° Turn
 Jog zurück ins Line Up

- A Marker
 Walk
 --- Jog
 --- ext. Jog
 --- 3+ Back Up

Trail Horse LK 3

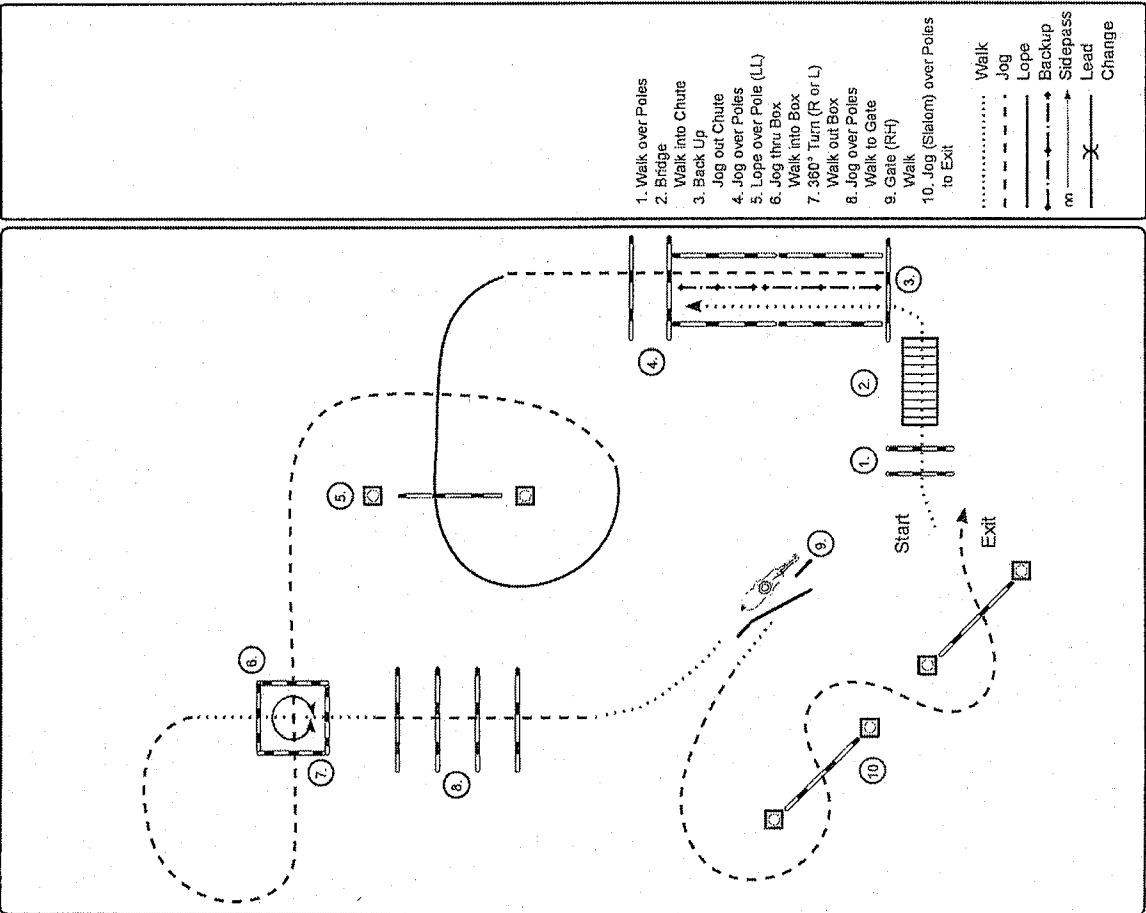

1. Walk over Poles
 2. Walk into Chute
 3. Back Up
 4. Jog over Poles
 5. Lope over Pole (LL)
 6. Jog thru Box
 7. Walk into Box
 8. 360° Turn (R or L)
 9. Walk out Box
 10. Jog over Poles
 Walk to Gate
 9. Gate (RH)
 Walk
 10. Jog (Slatom) over Poles to Exit

- Walk
 --- Jog
 --- Lope
 --- Backup
 --- Sidepass
 --- Lead
 --- Change

Showmanship at Halter LK 3A

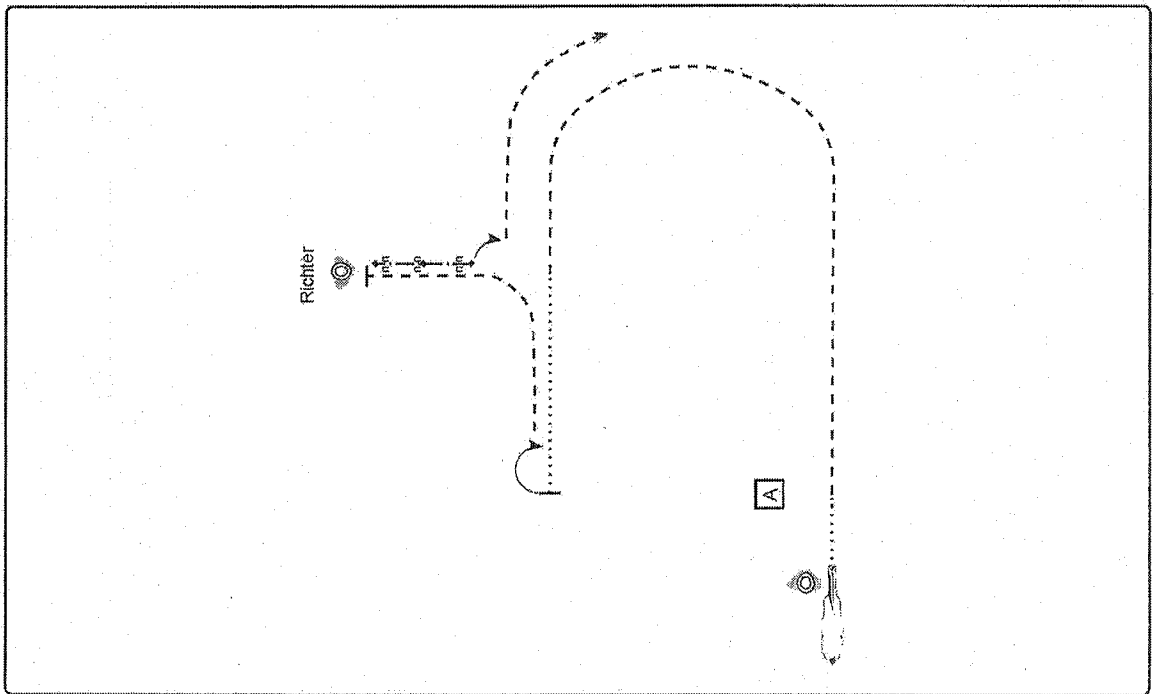

- Soll Up vor A
1. Walk als A
 2. einen halben Zirkel im Jog bis auf Höhe des Richters
 3. Walk bis auf Höhe A - Stop
 4. 180° Turn
 5. Jog bis zum Richter - Stop
 6. Soll Up
 7. Back Up
 8. 90° Turn
- Jog zurück ins Line Up

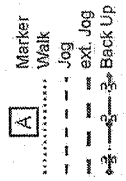

Showmanship at Halter LK 4-5A | B

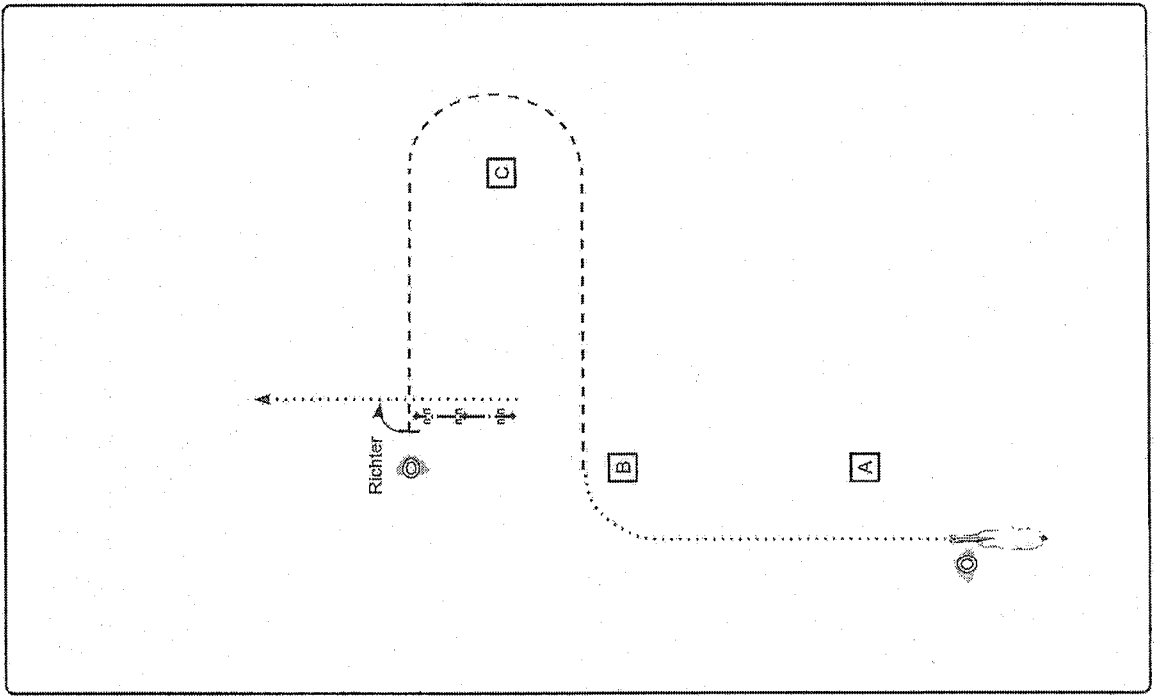

- Start vor A.
1. Walk bis B und um B herum
 2. bei B im Jog um C herum zum Richter - Stop
 3. Soll Up
 4. 90° Turn
 5. Back Up bis C
- Walk zurück ins Line Up

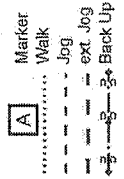

Western Horsemanship LK 3

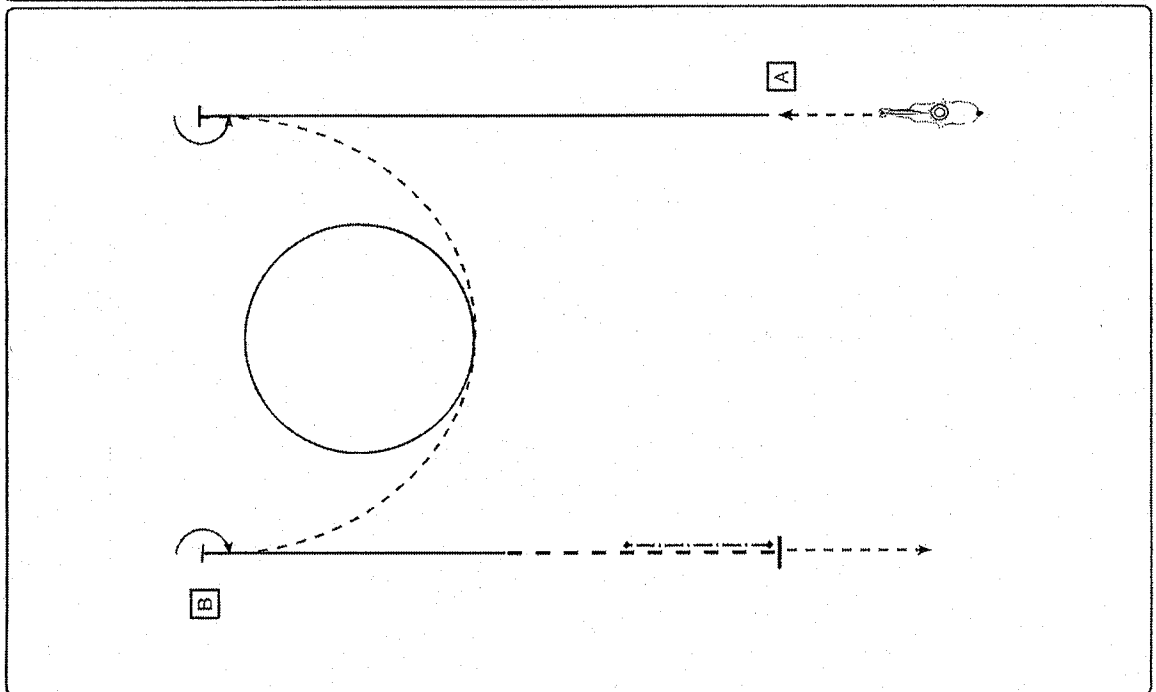

1. Jog zu A
2. Lope (L) bis auf Höhe B
3. Stop
4. 180° Turn (L)
5. Jog in einem halben Zirkel zu B und in der Mitte einen kleinen Zirkel im Lope (RL)
6. Stop
7. 180° Turn (R)
8. Lope (RL)/ext. Jog bis auf Höhe A - Stop
9. Back Up
10. Jog zum Ausgang

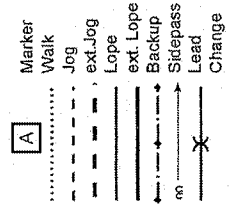

Western Horsemanship LK 1 / LK 2

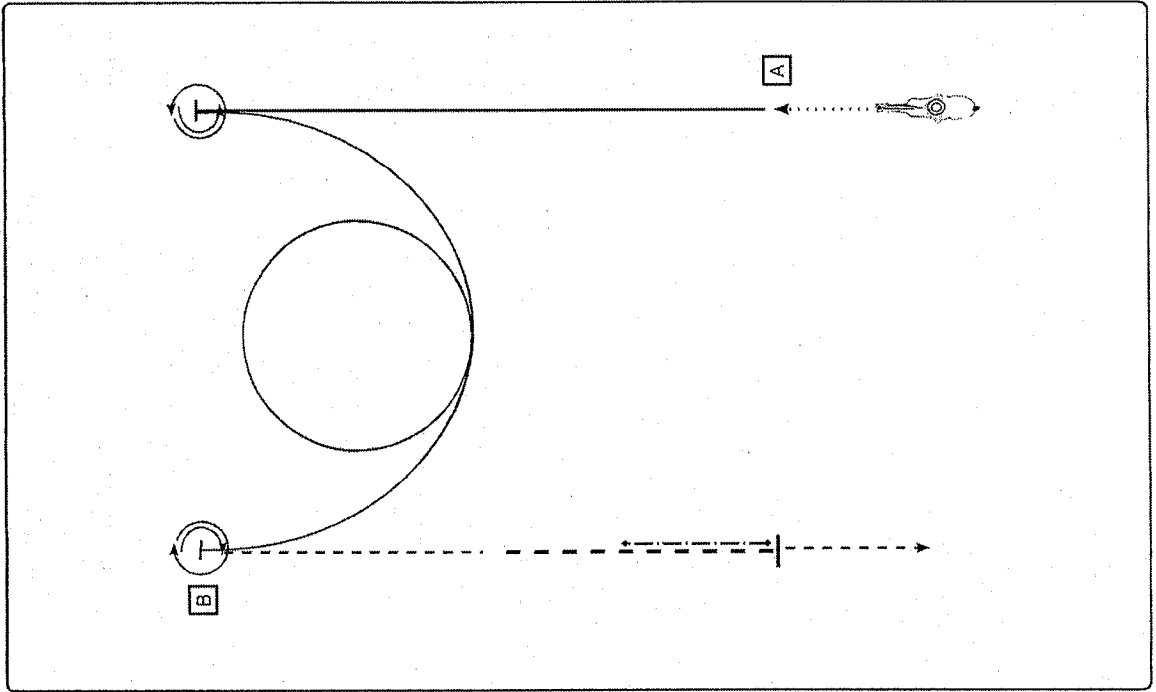

1. Walk zu A
2. Lope (L) bis auf Höhe B
3. Stop
4. 540° Turn (L)
5. Lope (RL) in einem halben Zirkel zu B und in der Mitte einen kleinen Zirkel
6. Stop
7. 540° Turn (R)
8. Jog/ext. Jog bis auf Höhe A
9. Stop
10. Back Up
11. Jog zum Ausgang

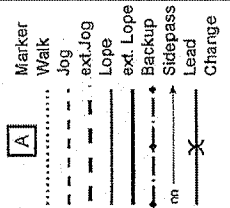

Western Horsemanship LK 4 A

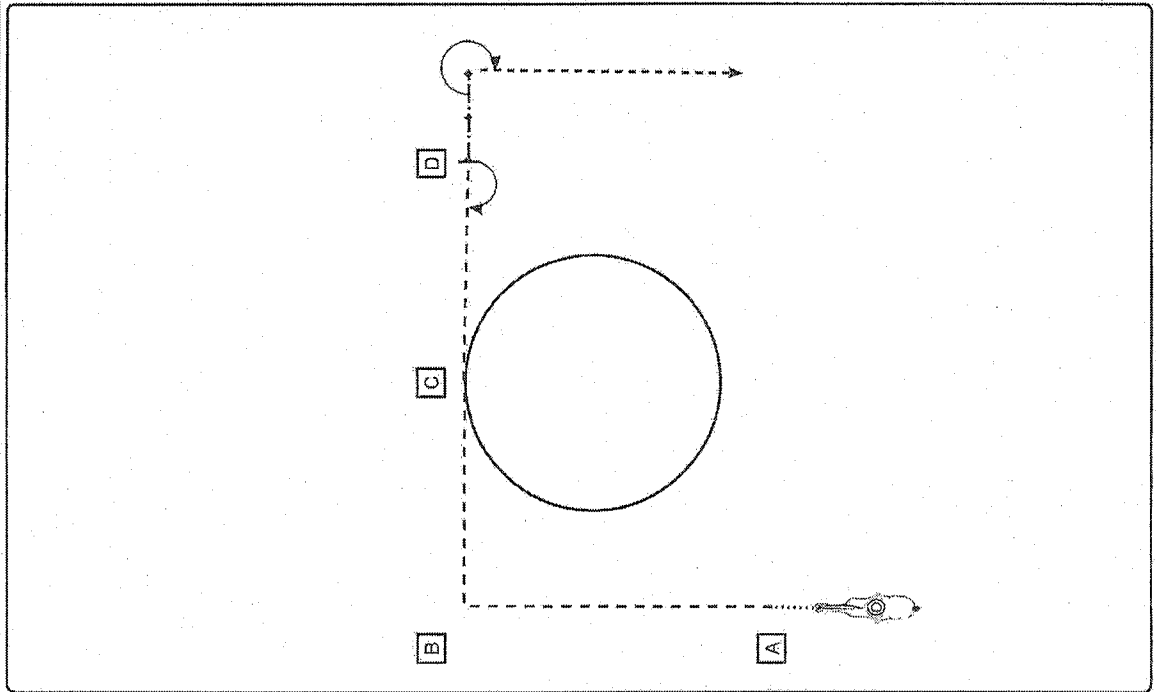

1. Walk bis A.
 2. Jog bis C
 3. bei C Lope (R/L) Zirkel
 4. Jog bis D - Stop
 5. Back Up
 6. 270° Turn (R).
- Jog zum Ausgang

A	Marker
.....	Walk
-----	Jog
-----	ext. Jog
-----	Lope
-----	ext. Lope
-----	Backup
-----	Sidepass
-----	Lead
-----	Change

Western Horsemanship LK 5 A / LK 5 B / LK 4 B

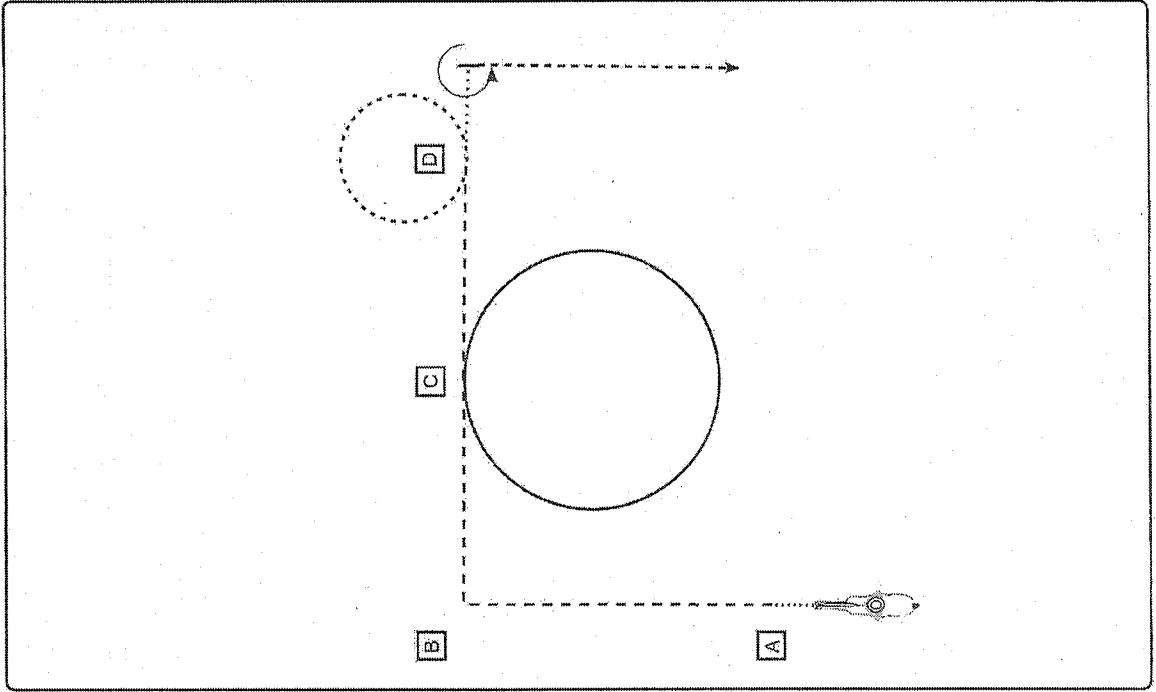

1. Walk bis A
 2. Jog bis C
 3. bei C Lope (R/L) Zirkel
 4. Walk Vorle um D und bis hinter D - Stop
 5. 270° Turn (L).
- Jog zum Ausgang

A	Marker
.....	Walk
-----	Jog
-----	ext. Jog
-----	Lope
-----	ext. Lope
-----	Backup
-----	Sidepass
-----	Lead
-----	Change

Western Horsemanship Walk-Trot

Walk Trot Western Horsemanship (Nr.1)

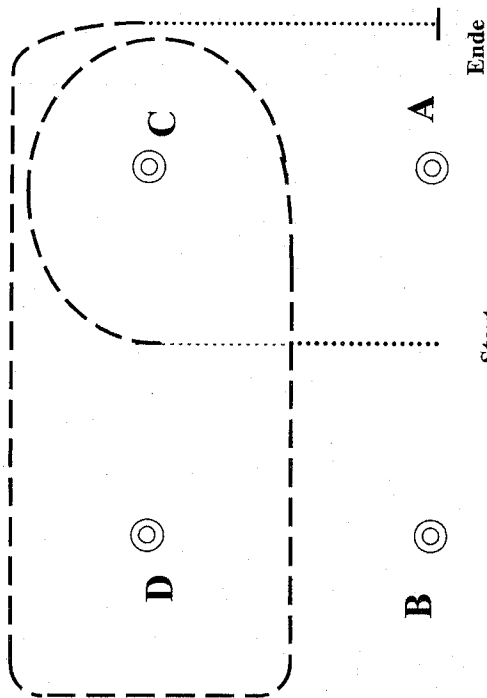

Beginn im Schritt zwischen A und B
 Zwischen C und D Jog
 Im Jog um C und D
 Bei C Schritt
 Stopp bei A

Im Schritt zurück zum Line Up

Horse & Dog Trail LK 1-2

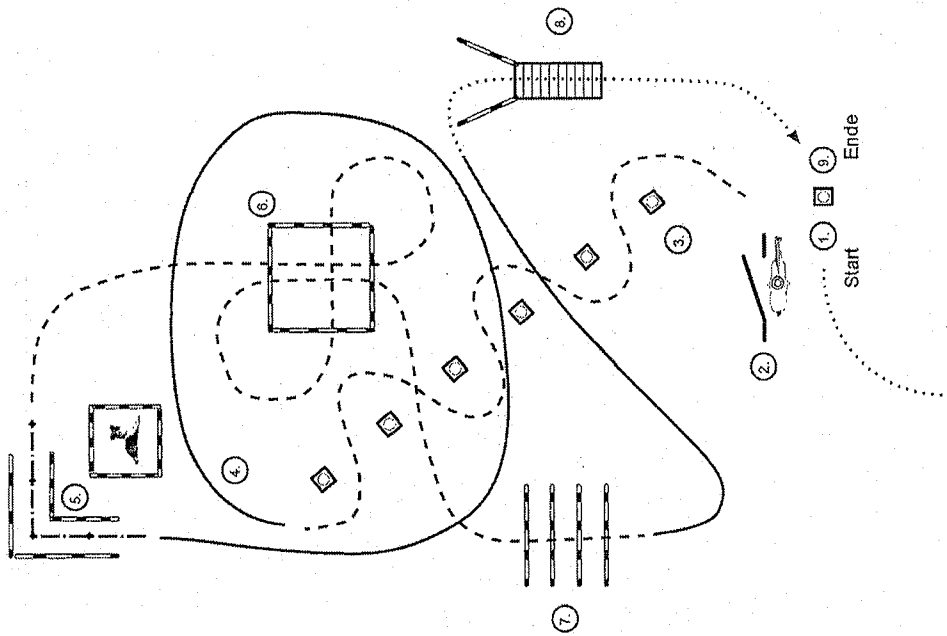

1. Einreiten
+ Hund ableinen
2. Tor
+ Hund vorausschicken
3. Jog Stalom
+ Hund bei Fuß
4. Rechtsgalopp
+ Hund bei Fuß
5. Back Up
+ Hund vorher im
Quadrat ablegen
6. Jog over:
+ Hund bei Fuß
+ Hund mit durch das
Quadrat
7. Jog over:
+ Hund bei Fuß
8. Linksgalopp, Walk,
Brücke
+ Hund vorausschicken
9. Absteigen
+ Hund anleinen

- A Marker
- Walk
 - Jog
 - ext.Jog
 - Lope
 - ext. Lope
 - Backkup
 - Sidepass
 - Lead
 - Change

Horse & Dog Trail LK 3-5

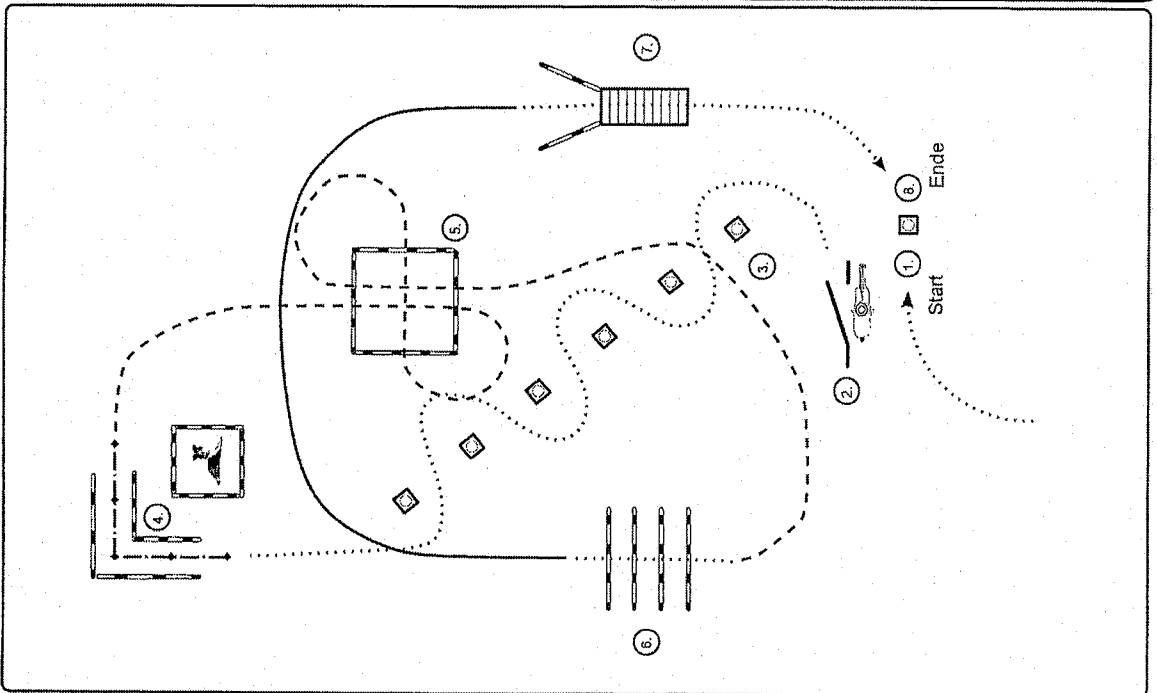

1. Einreiten
+ Hund ableinen
2. Tor
+ Hund voraus oder
nachhaken
3. Walk Slalom
+ Hund bei Fuß
4. Back Up
+ Hund vorher, im
Quadrat ablegen
+ danach Hund abrufen
5. Jog over
+ Hund bei Fuß
+ Hund mit durch das
Quadrat
6. Walk over
+ Hund bei Fuß
7. Rechtsgalopp zur Brücke
+ Hund bei Fuß
- Brücke
+ Hund voraus oder
nachkommen lassen
8. Absteigen
+ Hund anleinen

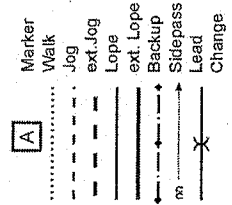

Ranch Trail LK 1-3 A

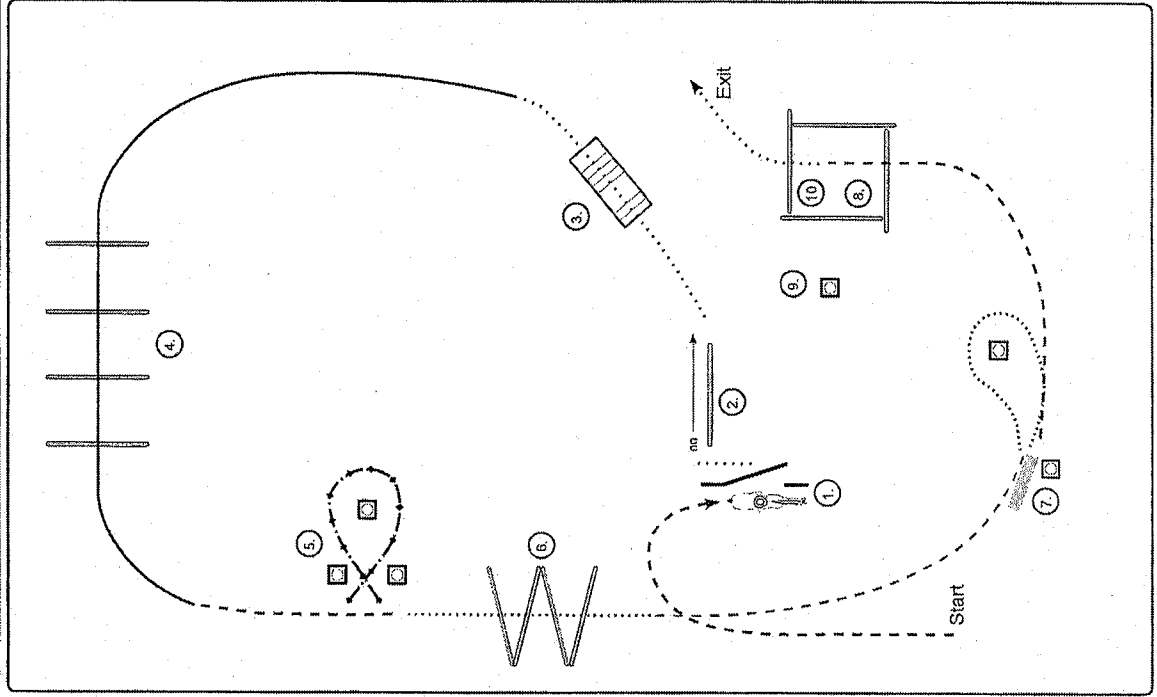

1. Tor
2. Seitwärts rechts
3. Brücke
4. Lope Over
5. Back Up
6. Walk Over
7. Log Drag
8. Ground Tie
9. Regenmantel anziehen
10. Aufsitzen, Walk Out

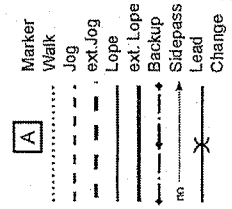

Ranch Riding

LK 1A/LK 2A

Since 10/2017

Pattern RR #2: LK 1/2 AB sen. Quail
Anfangsgröße: mind. 20x40m

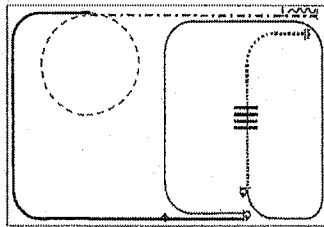

- 1) Rückwärts walk
- 2) Walk
- 3) Stop, 20° turn left
- 4) Walk
- 5) Stop, 30° turn right
- 6) Walk
- 7) Loop right hand, extended
- 8) Stop
- 9) Extended stop
- 10) Stop, back



LK 1B/LK 2B

Since 12/2017

Pattern RR #2: LK 1/2 AB sen. Quail
Anfangsgröße: mind. 20x40m

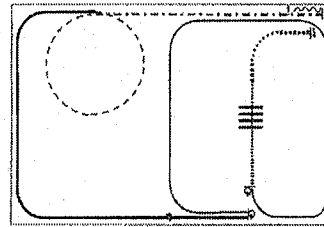

- 1) Extended walk
- 2) Walk
- 3) Stop, 20° turn left
- 4) Walk
- 5) Stop, 30° turn right
- 6) Walk
- 7) Loop right hand, extended
- 8) Stop
- 9) Extended stop
- 10) Stop, back



LK 3A/LK 3B

Since 10/2017

Pattern RR #7: LK3 AB
Anfangsgröße: mind. 20x40m

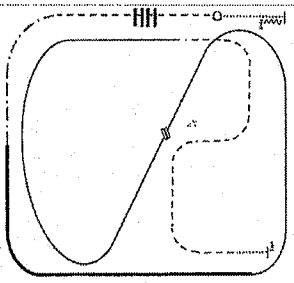

1. Walk
2. Trot
3. Stop
4. Change leads
5. Lope right lead
6. Lope left lead
7. Ext. Trot
8. Trot over
9. Stop, turn 180° each
10. Stop, back
11. Walk, Stop, Back



LK 4A/LK 4B

Since 10/2017

Pattern RR #5: LK 4/5 AB
Anfangsgröße: mind. 20x40m

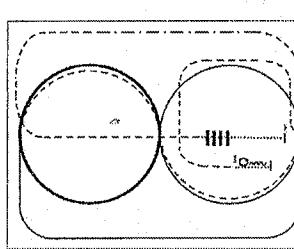

1. Walk over
2. Trot
3. Stop
4. Change leads
5. Lope right lead
6. Lope left lead
7. Ext. Trot
8. Stop, turn 180° each
9. Stop, back
10. Walk
11. Stop, Back
12. Stop, Back
13. Turn left 180°



Ranch Trail LK 1-3 B

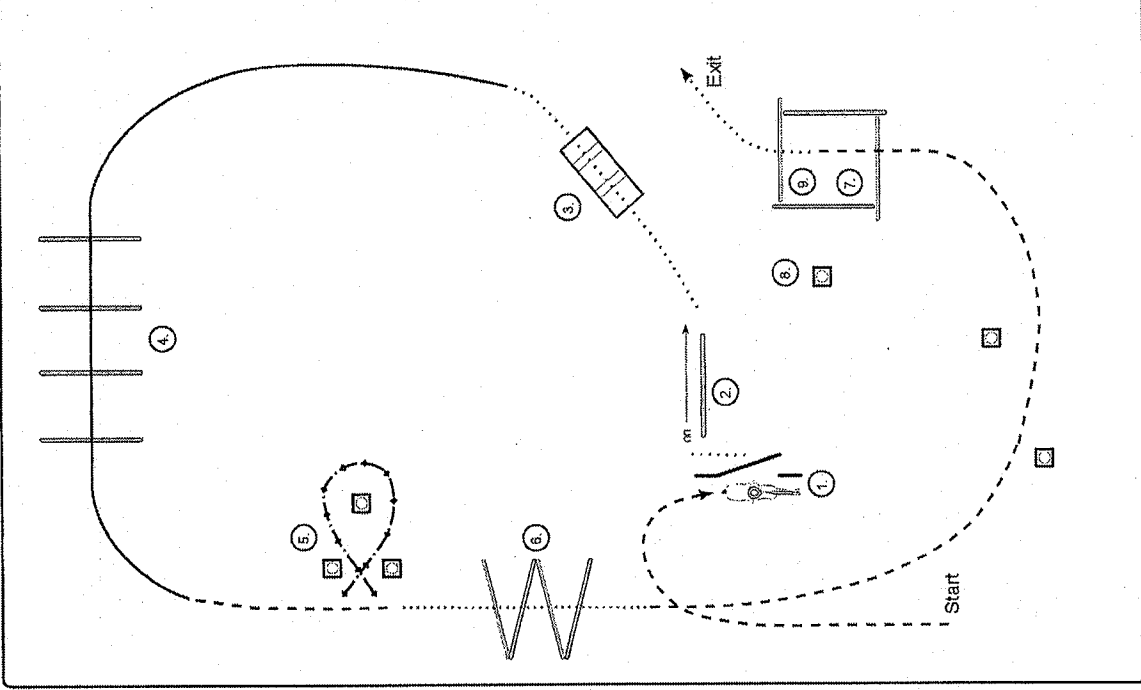

1. Tor
2. Seitwärts rechts
3. Brücke
4. Lope Over
5. Back Up
6. Walk Over
7. Ground Tie
8. Regenmantel anziehen
9. Aufsitzen, Walk Out

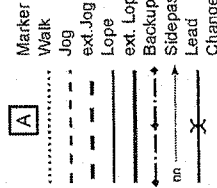

TRAIL FOR TWO

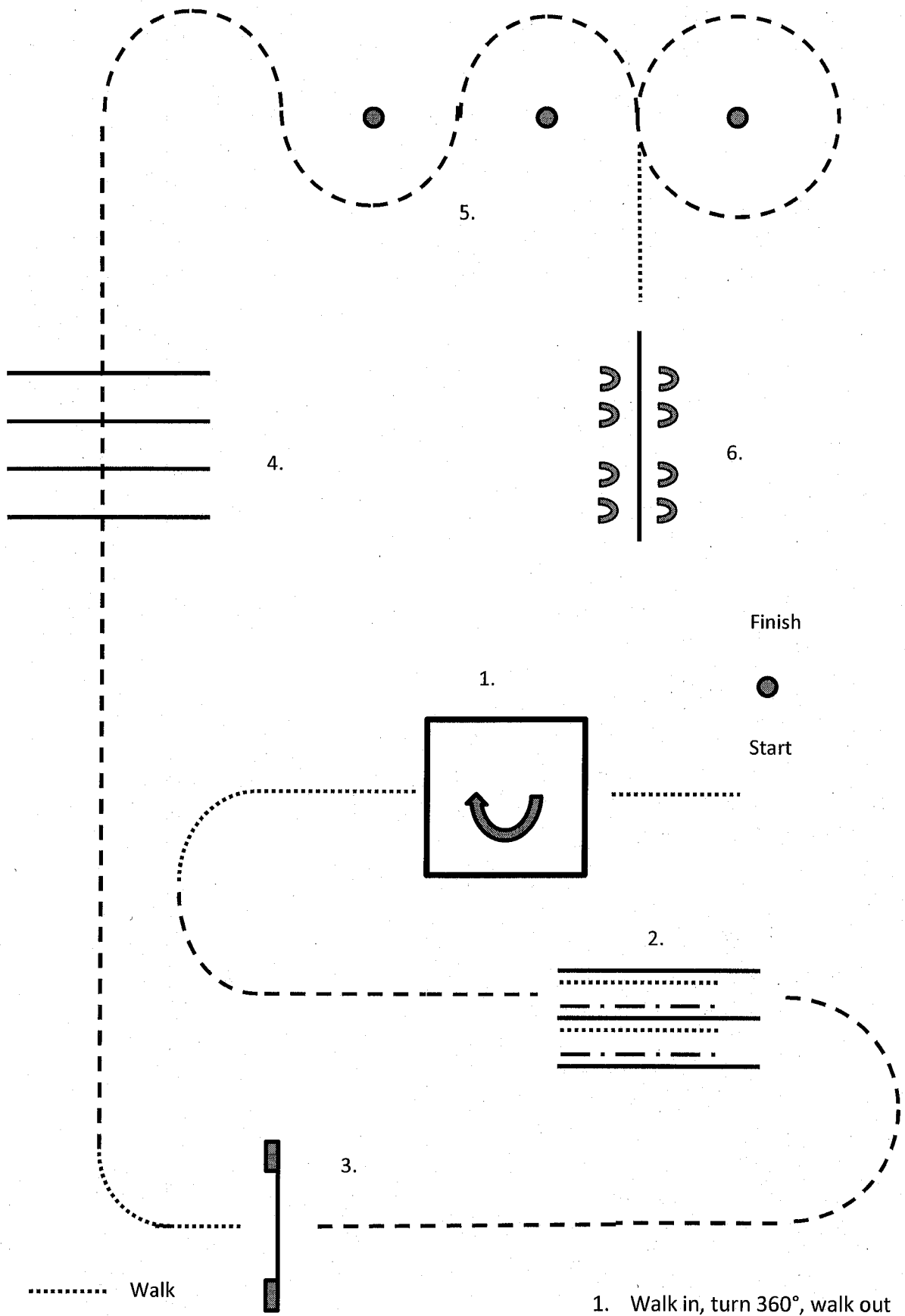

- Walk
- - - Trot
- . - Back-up
- ⤵ ⤵ Side-pass

1. Walk in, turn 360°, walk out
2. Walk in, back-up, walk out
3. Gate
4. Jog over
5. Slalom
6. Side-pass right